



EREDI DI ALLAIS SERGIO
di ALLAIS BRUNO



Nel 1967 nasce l'azienda AUTORIPARAZIONI ALLAIS SERGIO fondata da SERGIO ALLAIS che ha iniziato l'attività come semplice officina meccanica di riparazione auto autorizzata LANCIA e GIANNINI.

Nell'arco degli anni successivi grazie all'esperienza e la professionalità acquisita vengono costruiti dei veicoli speciali che sapientemente pilotati da Franco Negro, Scanavino Roberto e da Bruno Allais ottengono il Titolo di Campioni Italiani Autocross.

La passione per i motori di Allais Sergio, la sua voglia di sperimentare e la sua straordinaria inventiva, nell'arco degli anni, hanno fatto sì che ottenesse diversi successi sperimentando, per esempio, la prima applicazione abbinando la turbina ad un compressore volumetrico addirittura un anno in anticipo rispetto l'uscita della storica LANCIA DELTA S4. In molti ricordano ancora la fantastica GOLF denominata "VOLTURBO" che Allais Sergio esibiva con soddisfazione nelle piste su ghiaccio del Sestriere e nei vari raduni. I figli Bruno, Gisella e Maria custodiscono il prototipo della GOLF VOLTURBO con gelosia ed orgoglio.

Ma la passione di Allais Sergio per i motori si spinge ancora oltre e, negli anni '90 decide di abbandonare il settore autoriparazioni per produrre direttamente i ricambi speciali per auto storiche e da competizione e quindi si trasferisce in Via Vittorio Emanuele 258 a Giaveno e crea quella che da sempre gli appassionati del settore automobilistico chiamano "LA CASA DI ALI-BABA", cioè un complesso che ora ha raggiunto i 2000 mq dove vengono costruiti artigianalmente ricambi per auto da competizione ed auto storiche.

In officina troviamo un reparto di rettifica, tornitura, fresatura dove ogni giorno vengono costruiti ricambi di motori per auto prestigiose, quali BUGATTI, FERRARI, MASERATI, ALFA ROMEO, LANCIA, FIAT ecc che partono dal periodo anteguerra fino ai giorni nostri. Troviamo anche un reparto di revisione motori, preparazione testate, equilibratura alberi motore oltre che un vasto magazzino ricambi.

Il 17 febbraio 2008 Allais Sergio purtroppo viene a mancare e lascia il timone della sua "Casa di Ali-Baba" nelle sapienti mani del figlio Bruno che fin da ragazzino ha dimostrato di aver nel sangue la stessa passione, la stessa capacità ed inventiva del padre.

Oggi Bruno Allais, coadiuvato dalle sorelle Gisella e Maria e da validi collaboratori, continua il sogno del compianto padre realizzando particolari di motori per auto prestigiose.

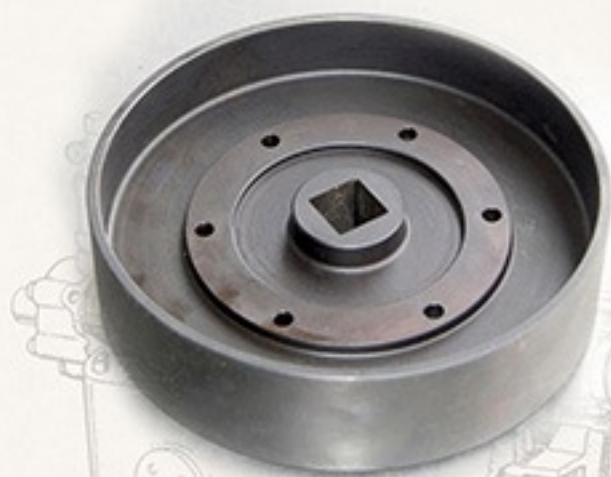

**AS 13001
TAMBURO FRENO
SUL CAMBIO**



**AS 13002
ALBERO A CAMMES IN ACCIAIO
LAVORATO DAL PIENO CON TRATTAMENTO
(DISPONIBILI DIVERSI PROFILI)**



**AS 13003
ALBERINO SUPERIORE
DISTRIBUZIONE CORTO**



**AS 13004
GIRANTE POMPA ACQUA**

AS 13005
DADO INTERNO SEMIASSE
(35 - 37 - 40)



AS 13006
COPPIA CONICA
(DISPONIBILE
IN DIVERSI RAPPORTI)



AS 13007
INGRANAGGIO
RETROMARCIA



AS 13008
VOLANO MOTORE



AS 13009
CROCE DIFFERENZIALE



AS 13010
PLANETARI DIFFERENZIALE
(KIT 4 PEZZI)



AS 13011
SATELLITE DIFFERENZIALE
(KIT 2 PEZZI)



AS 13012
COPERCHIO CARBURATORE
ZENITH

AS 13013
SUPPORTO CUSCINETTO
ALBERO A CAMMES
POSTERIORE



AS 13014
COPPIA
INGRANAGGI TRASVERSALI
COMANDO POMPA ACQUA

AS 13015
ALBERO DISTRIBUZIONE
INFERIORE LUNGO



AS 13016
FUSIONE POMPA OLIO 13

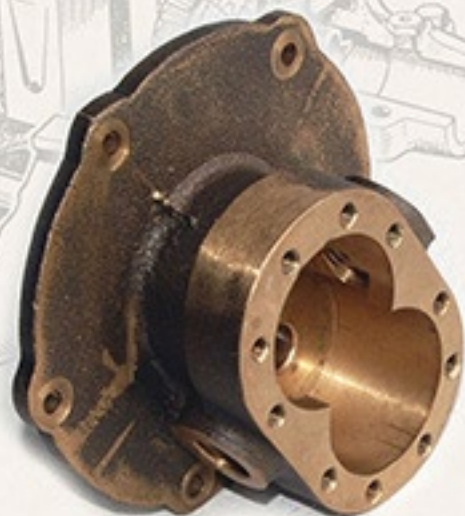

AS 13017
INGRANAGGIO
DISTRIBUZIONE INFERIORE



AS 13018
PRESA MANOVELLA
SU ALBERO MOTORE



AS 13019
TAPPI ALBERINO
TRASVERSALE DISTRIBUZIONE



AS 13020
BOCCOLA
ALBERO DISTRIBUZIONE
INFERIORE LUNGO



AS 13021
FLANGIA PIGNONE
DIFFERENZIALE
TRASMISSIONE



AS 13022
MOZZO RUOTA ANTERIORE
(FILETTO DX E SX)



AS 13030
MOZZO RUOTA POSTERIORE
(FILETTO DX E SX)



AS 13023
KIT INGRANAGGI
TANDEM MAGNETI



**AS 13024
SEMIASSE IN ACCIAIO**

**AS 13025
SCATOLA GUIDA**



**AS 13026
SCATOLA GUIDA
SENZA PIANTONE**

**AS 13027
KIT INGRANAGGI
COMPLETO**





AS 13028
SCATOLA DIFFERENZIALE

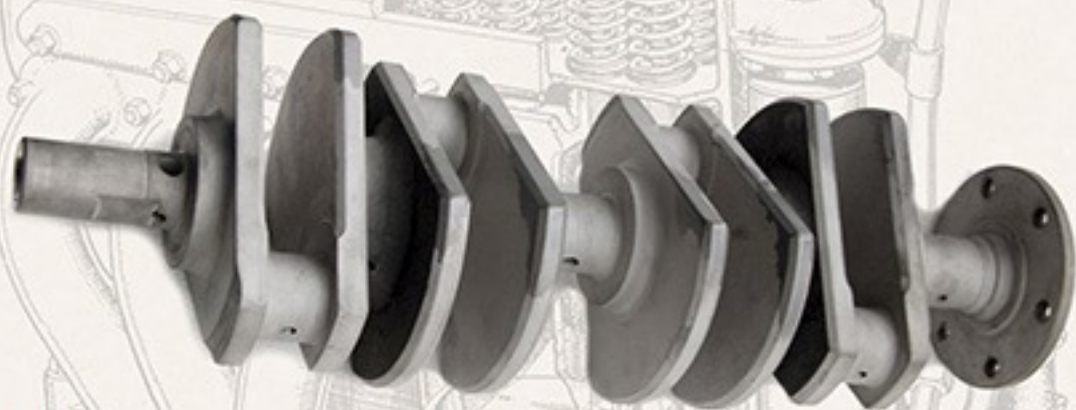

AS 13029
ALBERO MOTORE A PRESSIONE
IN ACCIAIO LAVORATO DAL PIENO



AS 13031
GIUNTO ALBERI DISTRIBUZIONE



**AS 35001
VOLANO MOTORE**

**AS 35002
PIGNONE DISTRIBUZIONE
ALBERO MOTORE
(CON E SENZA COMPRESSORE)**



**AS 35003
GIUNTO
ALBERI DISTRIBUZIONE**

**AS 35004
INGRANAGGIO
DISTRIBUZIONE ALBERO**



AS 35005
INGRANAGGI
COMANDO MAGNETE
USCITA ALBERO A CAMMES



AS 35006
ALBERO DISTRIBUZIONE INFERIORE LUNGO

AS 35007
DADO INTERNO SEMIASSE



AS 35008
GHIERA FERMO
DADO VOLANO MOTORE

AS 35009
INGRANAGGIO USCITA
ALBERO A CAMES



AS 35010
ALBERINO TRASVERSALE
COMANDO POMPA ACQUA CON GIUNTO



AS 35011
FLANGIA COMANDO
COMPRESSORE

AS 35012
FLANGIA COMANDO
COMPRESSORE





AS 35013
FLANGIA
COMANDO COMPRESSORE



AS 35014
INGRANAGGIO CASCATA
COMANDO COMPRESSORE



AS 35015
INGRANAGGIO COMANDO
CASCATA COMPRESSORE



AS 35016
INGRANAGGIO CASCATA
COMPRESSORE



AS 35017
INGRANAGGIO COMANDO
POMPA OLIO

AS 35018
INGRANAGGIO SUPERIORE
DISTRIBUZIONE CORTO



AS 35019
INGRANAGGIO
RETROMARCIA



AS 35020
ALBERO QUADRO FRIZIONE
(38 - 37 - 44 - 43 - 51)





**AS 35021
COPPIA CILINDRICA
(DISPONIBILE
IN DIVERSI RAPPORTI)**

**AS 35022
CROCE DIFFERENZIALE**

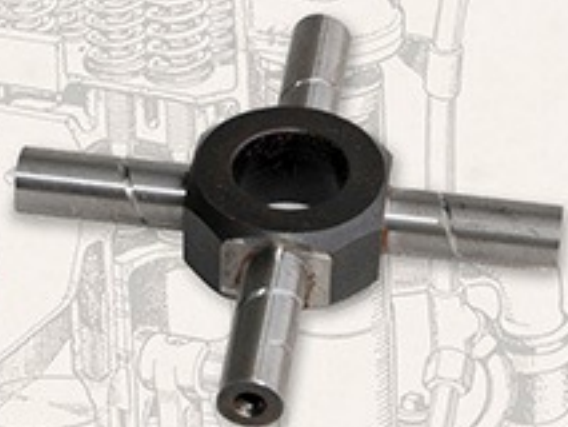

**AS 35023
PLANETARI DIFFERENZIALE
(KIT DI 4 PEZZI)**



**AS 35024
SATELLITE DIFFERENZIALE
(KIT DI 2 PEZZI)**



AS 35025
GIRANTE POMPA ACQUA



AS 35026
COPPIA
INGRANAGGI TRASVERSALI
COMANDO POMPA ACQUA



AS 35027
SCATOLA
DIFFERENZIALE
(37 - 38 - 43 - 44 - 51)





**AS 35028
FUSIONE
POMPA OLIO**

The image shows a detailed technical drawing of an engine block in the background. Overlaid on the top right is a photograph of a cast metal oil pump housing, which is a complex, multi-faceted component with a central opening and several mounting points.



**AS 35029
MOZZO
RUOTA POSTERIORE
E ANTERIORE 35/A**

The image shows a detailed technical drawing of an engine block in the background. Overlaid on the middle left is a photograph of a black, cylindrical axle component with a flange on one end and a threaded section on the other.



**AS 35030
FRIZIONE
SINTERIZZATA
(37 - 38 - 43 - 44 - 51)**

The image shows a detailed technical drawing of an engine block in the background. Overlaid on the bottom right is a photograph of a sinterized friction disc, which is a circular component with a central hole and several small holes around its perimeter.

AS 35031
PISTONI COSTRUITI IN
MATERIALE SPECIALE
LAVORATI DAL PIENO
POSSIBILITA' DI COSTRUIRE
TUTTE LE MAGGIORAZIONI
E MODIFICHE COMPRESSIONE



AS 35032
ALBERO MOTORE IN ACCIAIO
LAVORATO DAL PIENO A 5 SUPPORTI

AS 35033
SEMIASSE IN ACCIAIO



AS 35034
INGRANAGGIO
USCITA CAMBIO



AS 35035
INGRANAGGIO 3° E 4°
SCORREVOLE

AS 35036
INGRANAGGIO 1° E 2°
SCORREVOLE



AS 35037
ALBERO QUADRO ENTRATA CAMBIO
(SPECIFICARE SE A 14 O 15 DENTI)



AS 35038
FLANGIA ALBERO
ENTRATA CAMBIO



AS 35039
ALBERO LATERALE CAMBIO
PORTA INGRANAGGI



AS 35040
INGRANAGGI FISSI
(DA SX 1° - 2° - 3° - 4°)

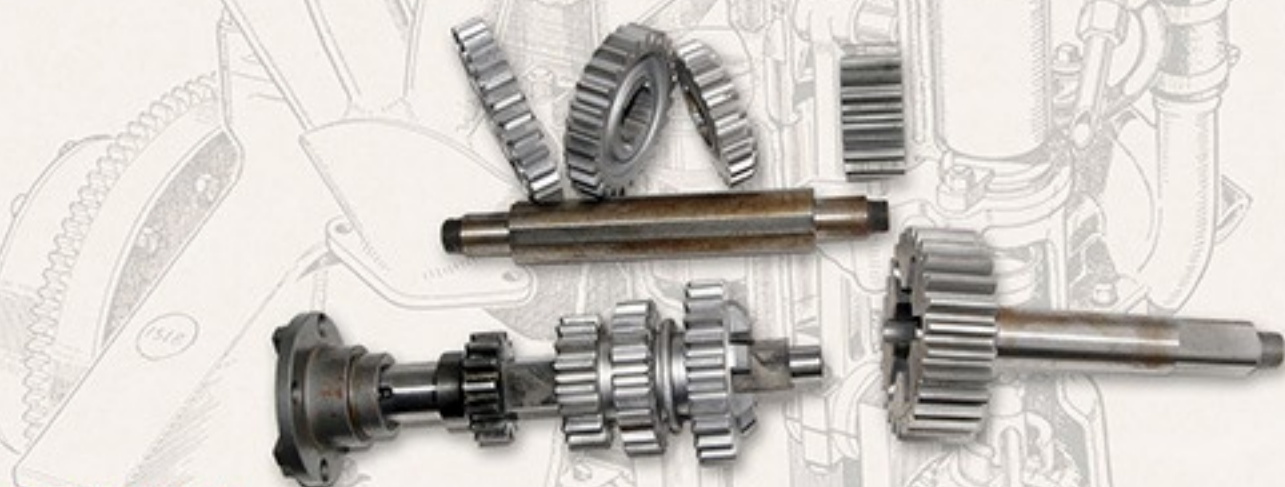

AS 35041
KIT INGRANAGGI COMPLETO



AS 35042
DADO INTERNO SEMIASSE



**AS 37001
VOLANO MOTORE**



**AS 37002
RANELLA RASAMENTO
INGRANAGGIO DISTRIBUZIONE
PRESA MOTORE**



**AS 37003
GIRANTE
POMPA ACQUA
(37A)**



**AS 37004
GIRANTE POMPA ACQUA
(40)**

AS 37005
DADO INTERNO SEMIASSE



AS 37006
INGRANAGGI
DISTRIBUZIONE
INFERIORI



AS 37007
COPPIA CONICA
(DISPONIBILE IN
DIVERSI RAPPORTI)



AS 37008
INGRANAGGIO COMANDO
POMPA OLIO

AS 37009
FUSIONE POMPA OLIO

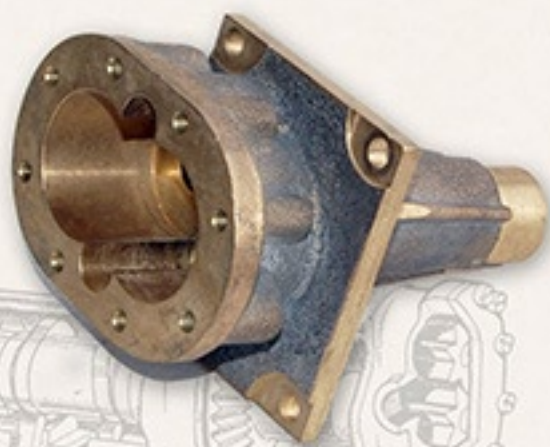

AS 37010
MOZZO
RUOTA ANTERIORE
E POSTERIORE
(FILETTO DX O SX)



AS 37011
PISTONI COSTRUITI
IN MATERIALE SPECIALE
LAVORATI DAL PIENO
POSSIBILITA' DI COSTRUIRE
TUTTE LE MAGGIORAZIONI
E MODIFICHE COMPRESIONE





**AS 37012
SEMIASSE IN ACCIAIO**



**AS 37013
DADO INTERNO SEMIASSE**



**AS 37014
KIT INGRANAGGI COMPLETO**



AS 40001
ALBERINO RETROMARCIA



AS 40002
PEDANA 40 SPIDER

AS 40003
DADO INTERNO SEMIASSE



AS 40004
MOZZO RUOTA POSTERIORE
(FILETTO DX O SX)

AS 44001
INGRANAGGIO
COMANDO POMPA OLIO
(38 - 44 - 51)

AS 44002
COPPIA INGRANAGGI
COMANDO
POMPA OLIO

AS 44003
INGRANAGGIO
RETROMARCIA
(38 - 40 - 51)



AS 44004
ALBERO ENTRATA CAMBIO
(40 - 38 - 51)

AS 44005
INGRANAGGIO
SCORREVOLE 3° - 4°
(40 - 38 - 51)

AS 44006
INGRANAGGI FISSI
CAMBIO 4° - 3° - 2°
(40 - 38 - 51)





AS 44007
ALBERO FISSO 1° E RETRO
(40 - 38 - 51)



AS 44008
ALBERO QUADRO USCITA CAMBIO
(40 - 38 - 51)



AS 44009
CORONA VOLANO
(43)



AS 44010
SEMIASSE ACCIAIO
(38 - 43)

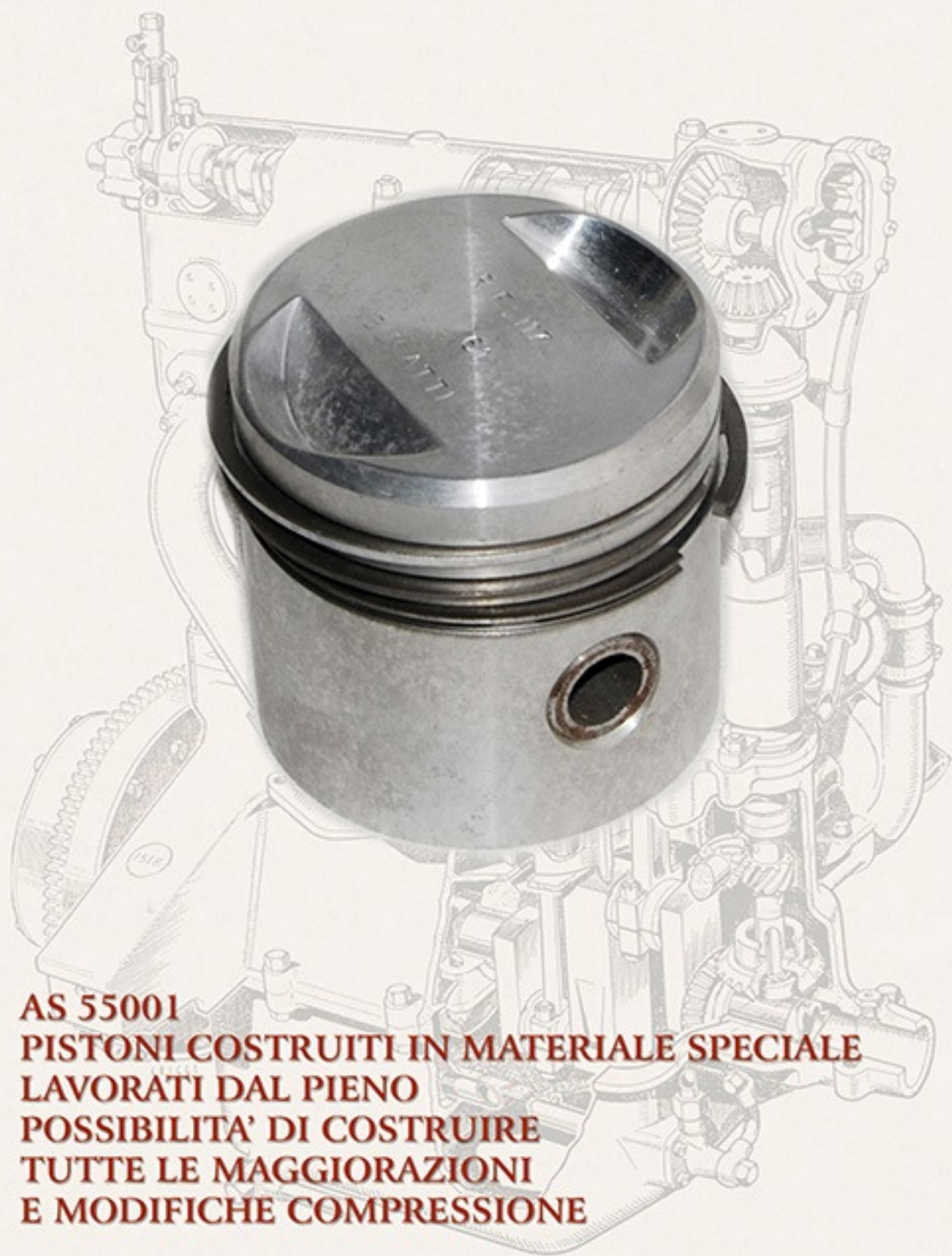

AS 55001
PISTONI COSTRUITI IN MATERIALE SPECIALE
LAVORATI DAL PIENO
POSSIBILITA' DI COSTRUIRE
TUTTE LE MAGGIORAZIONI
E MODIFICHE COMPRESSIONE

AS 57001
ALBERO POMPA ACQUA

AS 57002
INGRANAGGI
COMANDO
POMPA ACQUA

AS 57003
PISTONI COSTRUITI
IN MATERIALE SPECIALE
LAVORATO DAL PIENO
POSSIBILITA' DI COSTRUIRE
TUTTE LE MAGGIORAZIONI
E MODIFICHE COMPRESSIONE





**AS 57004
DISTRIBUZIONE**

**AS 57005
FUSIONE
CORPO COMPRESSORE**

**AS 57006
COPERCHI
LATERALI COMPRESSORE**

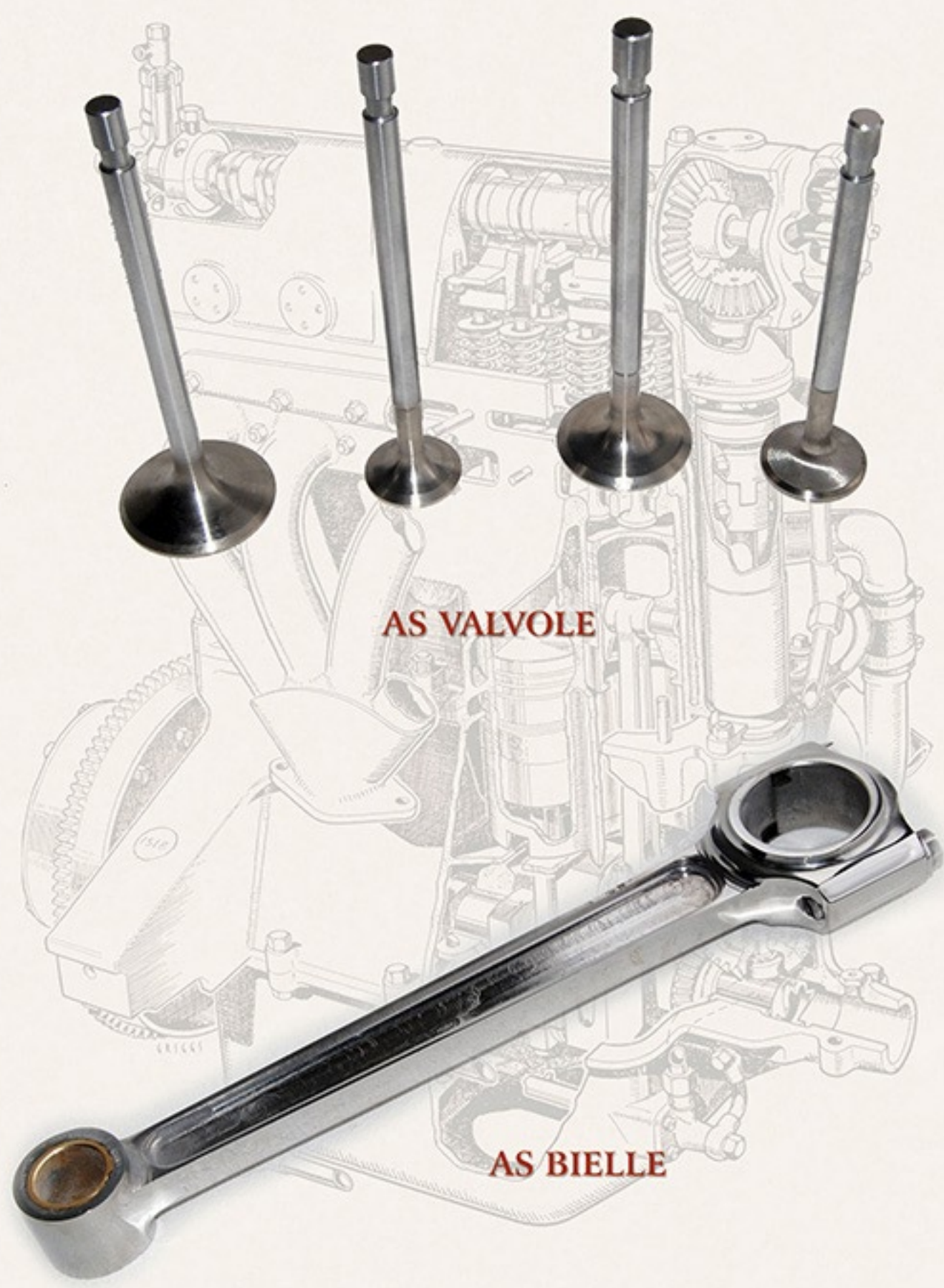

AS VALVOLE

AS BIELLE

**AS 13030
SCATOLA GUIDA 13
CORPO LUNGO**



AS 37015 KIT ASTE PORTA BILANCERI



**AS 35043
MOZZO
RUOTA POSTERIORE**

AS 13032
TESTA NODO STERZO



AS 35043
INGRASSATORE
POMPA ACQUA COMPLETO
(35 - 37 - 51 - 43 - 38 ECC.)



AS 35044
CUNEO CONICO
IN ALLUMINIO TIRANTE
DIFFERENZIALE
(35 - 37 - 51 - 43 - 38 ECC.)



AS 35045
FUSIONI SUPPORTI
ASTE CAMBIO
(35 - 37 - 51)

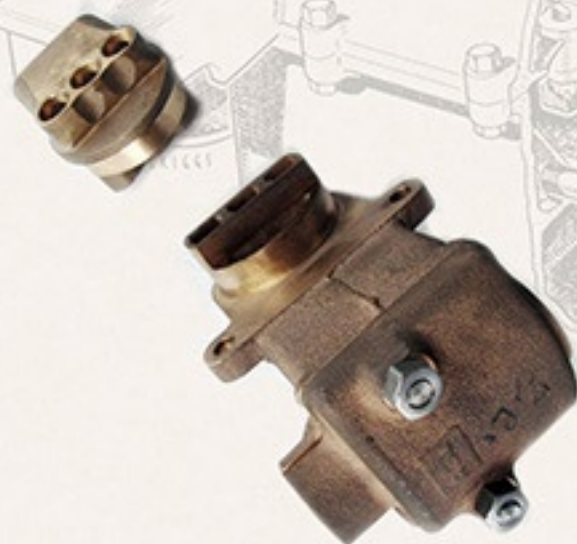

AS 35046
GIUNTO DIABLO
ACCOPIAMENTO
FRIZIONE E CAMBIO
(35 - 37)

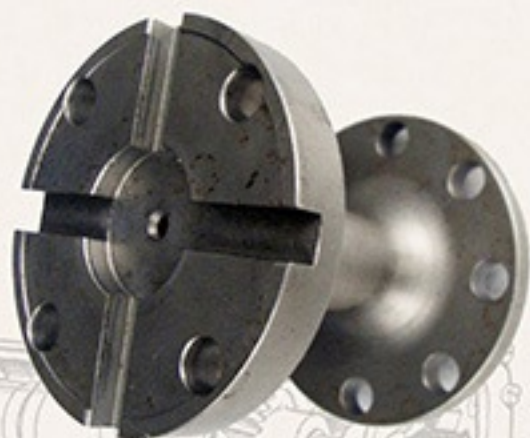

AS 35047
TESTA STERZO SNODO
(35 - 37 ECC.)



AS 35048
REGISTRO FILETTATO
TIRANTE DIFFERENZIALE
(35 - 37 - 51)



AS 35049
TESTA ACCELERATORE
CARBURATORI
(35 - 37 ECC.)

AS 35042
SERIE INGRANAGGI
CAMBIO COMPLETO
(TIPO CORSA)
(35 - 37 - 51)





EREDI DI ALLAIS SERGIO
di ALLAIS BRUNO

Via Vittorio Emanuele, 258
Tel. Fax 0039-0-119376401 - 0039-0-119375715
10094 GIAVENO (Torino) ITALIA

www.sergioallais.com

allais@nevib.it - info@sergioallais.com